

Heavy Duty Compression Load Cell



ATEX

DESCRIPTION

Model 122 is a heavy duty general purpose compression load cell particularly well suited for hopper and tank weighing and many other large scale industrial applications, including weighbridges for truck weighing.

The simple, compact column design and rugged hermetically sealed construction of the model 122 load cell assures its long term life in all types of field installations.

The model 122 load cell is often used in multi-cell installations, therefore its standard output tolerance is within 0.1%.

The two additional sense wires feed back the voltage reaching the load cell. Complete compensation of changes in lead resistance due to temperature change and/or cable extension, is achieved by feeding this voltage into the appropriate electronics.

FEATURES

- Capacities 50 - 150 ton
- Ideal for multi-cell applications
- Compact, economical, column design
- Hermetically sealed to IP68
- 6 Wire (sense) circuit
- Stainless steel housing as standard

APPLICATIONS

- Hopper and tank weighing
- Truck weighbridges

OUTLINE DIMENSIONS in millimeters

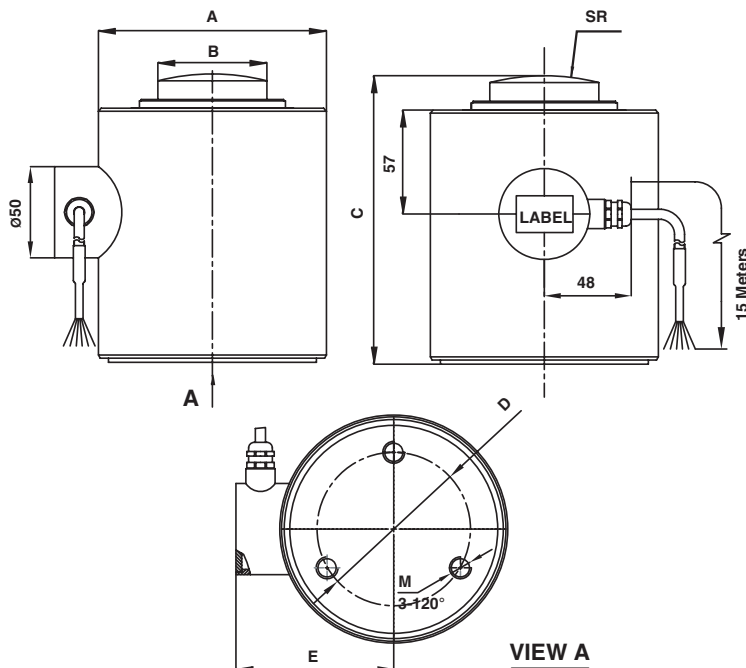

CAPACITY	A	B	C	D	E	M	SR
50T	Ø88	Ø45	122	Ø50	69	M10	SR35
100T, 150T	Ø125	Ø59.8	158	Ø84	86.5	M12	SR120

SPECIFICATIONS				
PARAMETER	VALUE			UNIT
Rated capacity-R.C. (E_{max})	50	100	150	ton
NTEP/OIML Accuracy class	Non-Approved ⁽¹⁾			
Maximum no. of intervals (n)	2000			
$Y = E_{max}/V_{min}$	2000			
Rated output-R.O.	1.5		2	mV/V
Rated output tolerance	0.0015			±mV/V
Zero balance	0.015		0.02	±mV/V
Zero Return, 30 min.	0.030			±% of applied load
Total Error (per OIML R60)	0.030			±% of rated output
Temperature effect on zero	0.03			±% of rated output/°C
Temperature effect on output, unbalanced	0.0080 ⁽²⁾			±% of load/°C
Temperature range, compensated	5 to +45			°C
Temperature range, safe	-20 to +60			°C
Maximum safe central overload	150			% of R.C.
Ultimate central overload	200			% of R.C.
Excitation, recommended	10			Vdc or Vac rms
Excitation, maximum	15			Vdc or Vac rms
Input impedance	670±15	1270±20	1350±30	Ohm
Output impedance	600±5	1205±5	1205±5	Ohm
Insulation resistance	>2000			Mega-Ohm
Cable length	15			m
Cable type	6 wire, braided, PVC, single floating screen			Standard
Construction	Stainless steel housing, plated alloy steel sensor			
Environmental protection	IP68			

Notes

- (1) Typical 80% utilization
- (2) Balanced span compensation is available upon request

WIRING SCHEMATIC DIAGRAM
(unbalanced bridge configuration)

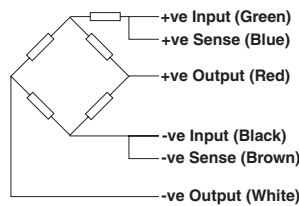

Disclaimer

All product specifications and data are subject to change without notice.

Vishay Precision Group, Inc., its affiliates, agents, and employees, and all persons acting on its or their behalf (collectively, "Vishay Precision Group"), disclaim any and all liability for any errors, inaccuracies or incompleteness contained herein or in any other disclosure relating to any product.

Vishay Precision Group disclaims any and all liability arising out of the use or application of any product described herein or of any information provided herein to the maximum extent permitted by law. The product specifications do not expand or otherwise modify Vishay Precision Group's terms and conditions of purchase, including but not limited to the warranty expressed therein, which apply to these products.

No license, express or implied, by estoppel or otherwise, to any intellectual property rights is granted by this document or by any conduct of Vishay Precision Group.

The products shown herein are not designed for use in medical, life-saving, or life-sustaining applications unless otherwise expressly indicated. Customers using or selling Vishay Precision Group products not expressly indicated for use in such applications do so entirely at their own risk and agree to fully indemnify Vishay Precision Group for any damages arising or resulting from such use or sale. Please contact authorized Vishay Precision Group personnel to obtain written terms and conditions regarding products designed for such applications.

Product names and markings noted herein may be trademarks of their respective owners.